

# Science

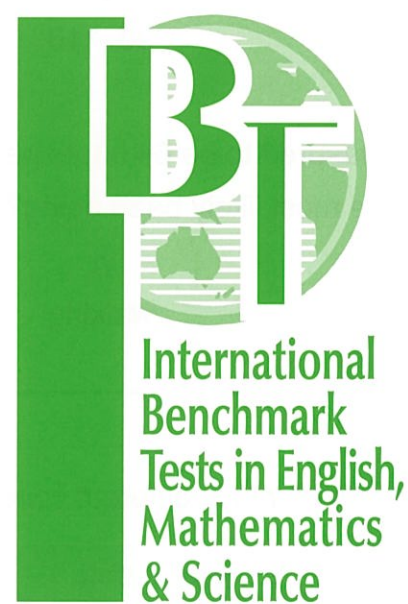

STUDENT NAME \_\_\_\_\_

NAME OF SCHOOL \_\_\_\_\_

### TEST INSTRUCTIONS

#### FILL IN YOUR DETAILS

Turn to your ANSWER SHEET and fill in your name, school, grade, section, today's date, your date of birth and gender.

#### ANSWERING QUESTIONS

Go to the SCIENCE ANSWER SHEET.

This test has **40 QUESTIONS**. Each question has four possible options.

Choose the **BEST** answer from the four options, **A, B, C** or **D**.

FILL in **ONE** circle on your answer sheet with a pencil.

If you make a mistake, erase the pencil mark and fill in a different circle.

You must colour the entire circle as shown below:

<p><b>Correct response</b></p>	<p><b>Incorrect responses</b></p>
	<p>Line    Very light pencil    Pen    Colored pencil</p>

Marks are NOT deducted for incorrect answers.

**ALL ANSWERS SHOULD BE MARKED ON YOUR ANSWER SHEET ONLY.**

#### EQUIPMENT ALLOWED IN THIS TEST

You may use a 2B or B pencil for this test. You may NOT use a dictionary for this test.

#### TIME ALLOWED FOR TEST

The time allowed to complete this test is **60 minutes**.

1 Anwar grew rice on his farm.



Rice plants

Which tool should he use to harvest the crop?

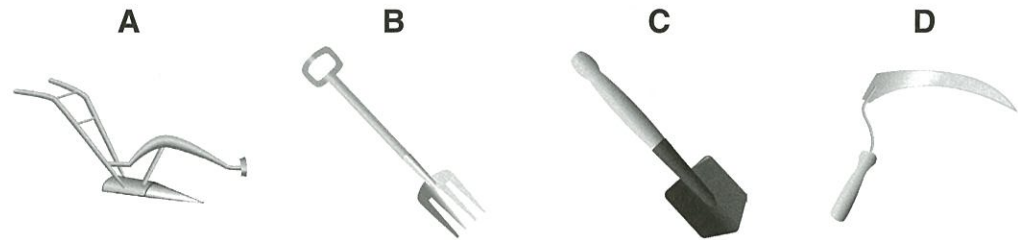

2 Rajeev had two fresh slices of bread.

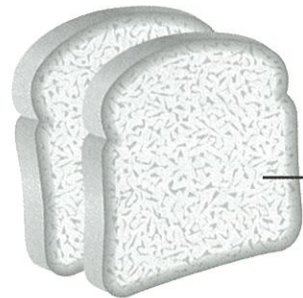

bread slice

The table shows how he stored each slice.

Slice	How it was stored	What happened after 3 days
1	left in the open	mould growing on the slice
2	placed in a plastic box and covered	slice appears unchanged

Rajeev travels for two days.

How can he keep the bread fresh?

- A seal it in a plastic bag
- B carry it in an open basket
- C spread butter on its surface
- D sprinkle water on its surface

The table shows the average heart rate of high school students for different activities.

Activity	Average heart rate (beats per minute)
Running	130–160
Sleeping	55–65
Walking	90–115

38 What would be the most likely average heart rate during swimming, for the same group?

- A 40–50
- B 55–70
- C 90–110
- D 125–155

39 A student's heart rate was measured to be 64 beats per minute. Which of the following had she most likely been doing?

- A sleeping
- B running
- C walking
- D swimming

40 Mr. Roy grew four potted tomato plants in different conditions.

Plant	Watered daily with	Type of soil	Sunlight or dark
1	mineral water	sand	dark
2	tap water	sand	sunlight
3	salt water	clay	sunlight
4	mineral water	clay	dark

Which plant is likely to grow best?

- A Plant 1
- B Plant 2
- C Plant 3
- D Plant 4

35 The table shows some uses of fossil fuels.

Fossil fuel	Used in
diesel	cars, buses, trucks
petrol	cars, motorcycles
coal	industry, power plants
natural gas	industry, power plants

A car company launched two versions of a new small car.

Each car uses a different fuel.

Which types of fuel are most likely to be used in the cars?

- A coal and diesel
- B coal and petrol
- C petrol and diesel
- D diesel and natural gas

Hanna tested materials for how well they transfer heat. This is her experiment.

**Hanna's record**

Material	Temperature after 10 minutes (°C)
W	45
X	38
Y	25
Z	65

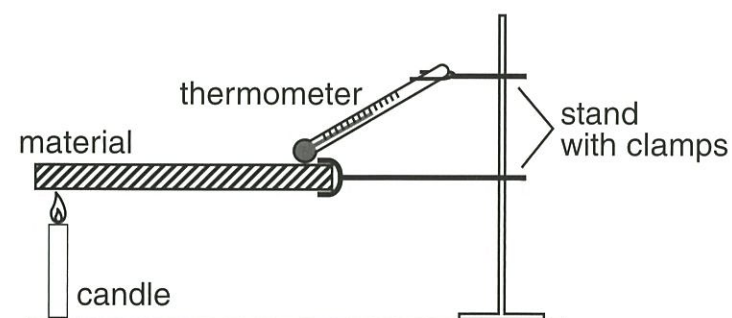

36 Which material would be best to use for a saucepan handle?

- |          |          |          |          |
|----------|----------|----------|----------|
| <b>A</b> | <b>B</b> | <b>C</b> | <b>D</b> |
| W        | X        | Y        | Z        |

37 What could Hanna do to make the experiment fair?

- A Repeat each test.
- B Use a new thermometer for each test.
- C Place softer materials further from the flame.
- D Check that each material starts at the same temperature.

3 Peter placed three different sheets between a candle and his eyes.

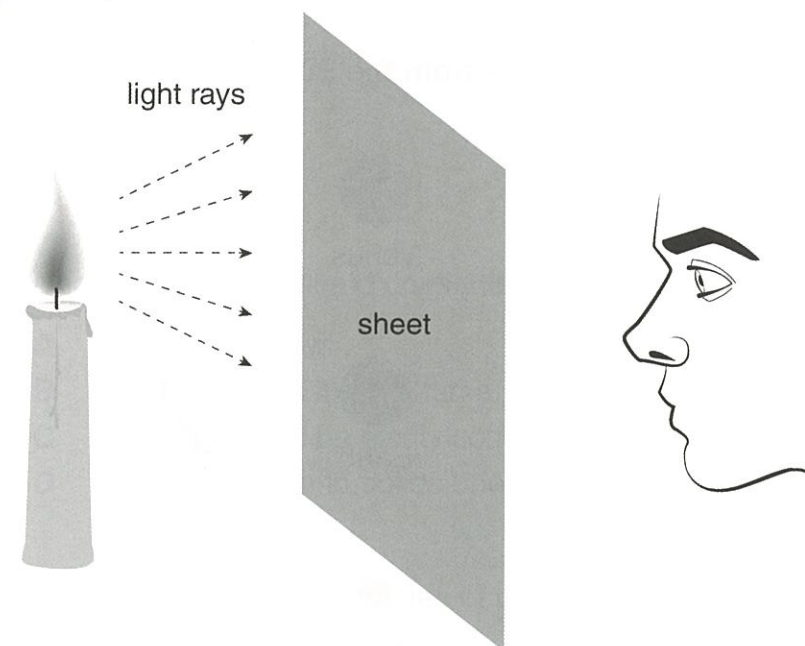

The table shows what he saw.

Sheet	What he saw
1	He could not see the candle.
2	He could see the candle clearly.
3	He could see the candle but not clearly.

What were sheets 1, 2 and 3 most likely made of?

Select the correct row.

	Sheet 1	Sheet 2	Sheet 3
<b>A</b>	glass	wood	tracing paper
<b>B</b>	wood	glass	tracing paper
<b>C</b>	tracing paper	glass	wood
<b>D</b>	wood	tracing paper	glass

4 In what way is a man-made satellite used?

- A to connect people's mobile phones
- B to manage the tides in rivers and oceans
- C to block ultraviolet rays from reaching the Earth
- D to control the weather of different areas on the Earth

Growing season is the time of the year that plants increase their size most quickly. The table shows the growing season for different plants.

	Growing season	Length of growing season
plant 1	all year	12 months
plant 2	June to July	2 months
plant 3	August to November	4 months
plant 4	November to April	6 months

11 Which plant grows in May?

- A plant 1      B plant 2      C plant 3      D plant 4

12 Which graph correctly shows the number of growing months for each plant?

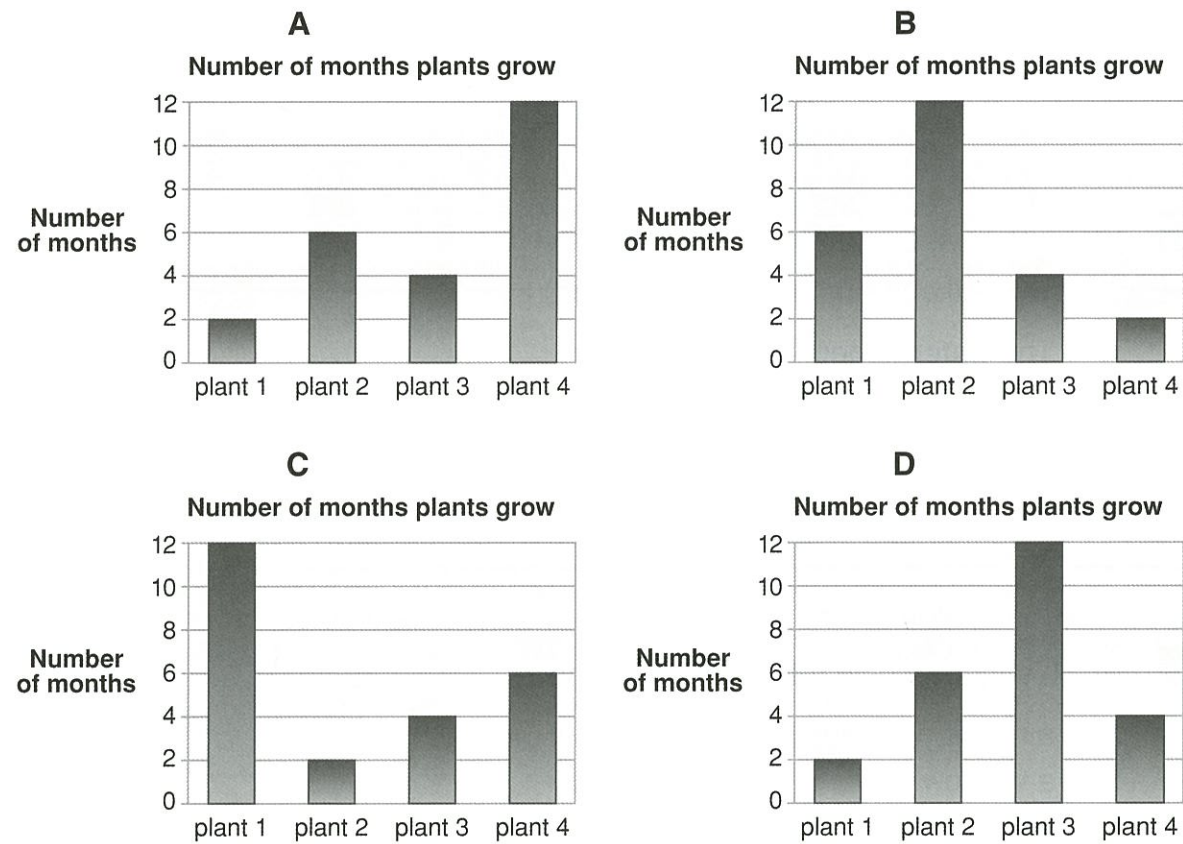

Five points on the Earth's surface are labelled in the picture.



26 A spacecraft is moving over land. Which labelled point could it be?

- A P      B Q      C R      D S

27 It is sunrise at point Q. At which other labelled point is it also daytime?

- A P      B R      C S      D T

28 A scuba diver sees a bird from under the water.

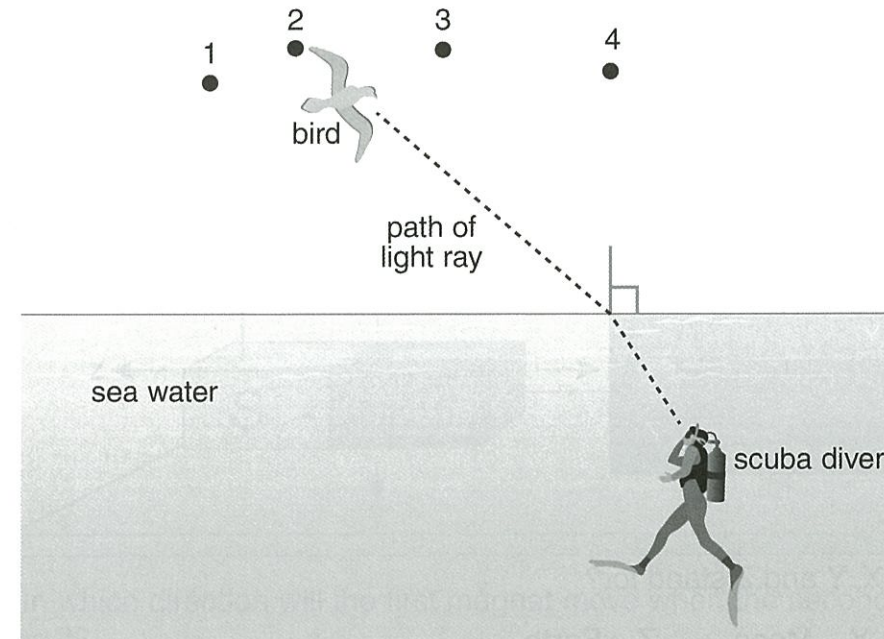

Where will the scuba diver think the bird is?

- A position 1      B position 2      C position 3      D position 4

23 Some smooth round stones are found at the edge of a river.

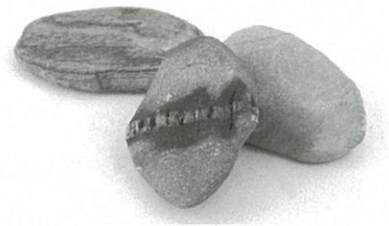

Why are the stones so smooth?

- A They have always been like this.
- B Wind blowing down the river valley smoothed the stones.
- C They were worn smooth by sand moving in the river.
- D Animals digging in the river bed smoothed the surface of the stones.

John dropped a football from the same height onto four types of floor. He measured how high the ball bounced on each floor.



Bounce height on different floors

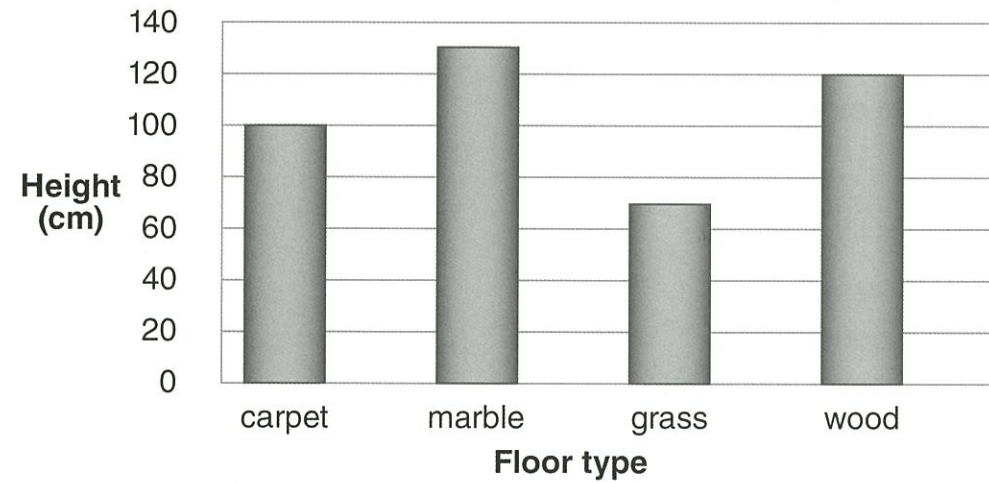

24 How high was the biggest bounce?

- A 100 cm
- B 120 cm
- C 130 cm
- D 140 cm

25 On which floor did the ball bounce the **least**?

- A carpet
- B marble
- C grass
- D wood

13 Which factors are likely to decide the growing season for a plant?  
Select the correct row.

	Temperature	Amount of water available
A	yes	no
B	no	yes
C	no	no
D	yes	yes

14 The used can in the picture was recycled to make a new can.

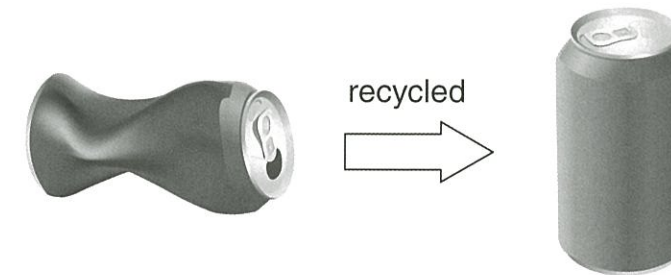

How does the can change state during recycling?

- A solid → liquid → gas
- B solid → liquid → solid
- C liquid → solid → liquid
- D solid → gas → solid

15 Which of these foods is the root of a plant?

- A apple
- B carrot
- C orange
- D lettuce

16 Which feature of this bird shows the type of food it eats?

- A the sound it makes
- B the size of its wings
- C the shape of its beak
- D the colour of its feathers



17 Why can copper wire conduct electricity?

- A It is hard.
- B It is shiny.
- C It is a metal.
- D It is found in nature.

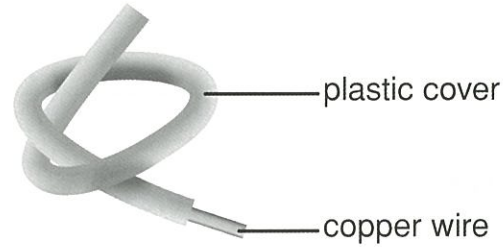

18 Why is the copper wire covered in plastic?

- A Plastic is light in weight.
- B Plastic does not melt when heated.
- C Plastic comes in different colours.
- D Plastic does not conduct electricity.

19 Sand dunes are small hills of sand found in deserts.

What causes sand dunes to form?

- A wind
- B rain
- C fire
- D sunlight

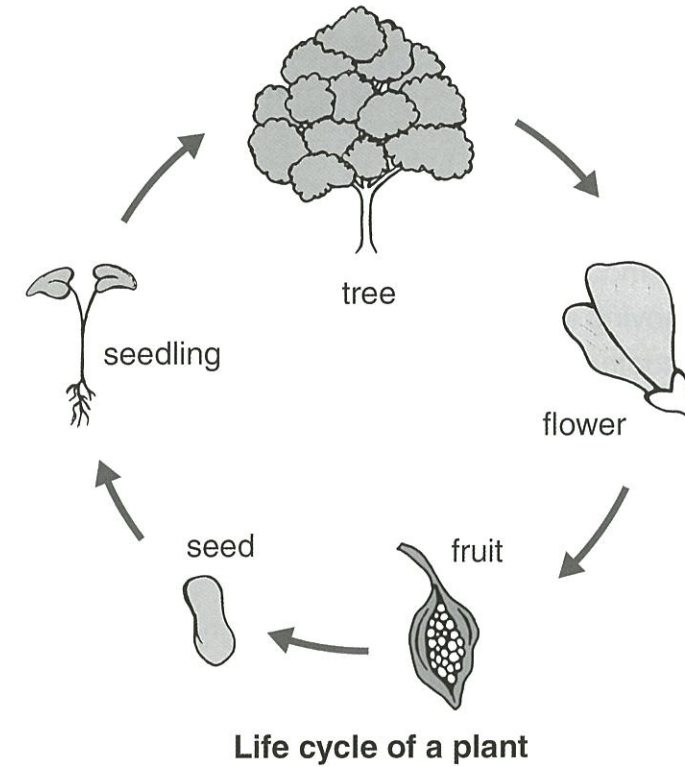

20 What is true for this life cycle?

- A A fruit produces a flower.
- B A seedling produces fruit.
- C A seed produces a new plant.
- D A flower produces a new tree.

21 At which stage of the life cycle do insects help the plant reproduce?

- A flower
- B fruit
- C seed
- D seedling

22 Which part of the plant makes food for the plant?

- A flowers
- B leaves
- C seeds
- D roots